

DENTAL X-RAY

PHOT-X II 303

OPERATOR'S INSTRUCTIONS

- Wall Mount TypeWK
- Floor Mount TypeFK1/FK2
- Mobile Type.....FM
- Room Mount TypeRK
- Ceiling Mount Type.....CK



⚠ WARNING

This X-ray equipment may be dangerous to patients and operators unless safe exposure factors and operating instructions are observed.

 Belmont®

INDEX

	PAGE
[1] INTRODUCTION -----	1
[2] MAJOR COMPONENTS-----	2
[3] FUNCTION OF CONTROLS-----	6
[4] OPERATING PROCEDURES -----	8
[5] HAND EXPOSURE SWITCH-----	9
[6] DIGITAL IMAGING SYSTEM -----	9
[7] CLEANING AND DISINFECTION -----	9
[8] DISPOSAL OF USED FILM AND CCD COVERS -----	9
[9] ERROR CODES -----	10
[10] MAINTENANCE -----	11
[11] TECHNICAL DATA -----	12
[12] ELECTROMAGNETIC COMPATIBILITY(EMC) -----	14

Intended Use of the Product

This product is an active device intended to emit ionizing radiation for the exclusive use for diagnoses of dentistry, and must be operated or handled by the qualified personnel only.

Such qualified personnel should instruct and/or assist the patient to approach to and leave from the product.

Patients should not be allowed to operate or handle the product.

It is always recommended that both operator and patient use the proper protective means for radiographing.

[1] INTRODUCTION

1. GENERAL

PHOT-X II MODEL 303 is a extraoral source dental radiographic x-ray unit. This unit works as a diagnostic purpose x-ray source for human teeth with resultant image recorded on intraoral dental x-ray film or image receptor.

This manual provides information for the operation and maintenance procedures and technical specifications for PHOT-X II MODEL 303 dental x-ray. The instructions contained in this book should be thoroughly read and understood before operation.

PHOT-X II MODEL 303 has no user serviceable items. Maintenance and repair should be performed by qualified dealer service personnel.

2. PARTS IDENTIFICATION OF X-RAY SYSTEM “PHOT-X II” MODEL 303

- a. Tube housing assembly : 303-H
- b. X-ray controls : 303-CM (main controller), 303-CS (sub controller)
- c. Cones : 303-R (regular), 303-L (long), 303-REC (rectangular)
- d. Balance arm : 303-A
- e. RK stand : 303-RK

3. COMPLIANCE WITH STANDARD

BELMONT PHOT-X II MODEL 303 x-ray unit complies with the following standard.

- EN60601-1 : 1990, EN60601-1-3 : 1994, EN60601-2-7 : 1998,
- EN60601-2-28 : 1993, EN60601-2-32 : 1994

4. CLASSIFICATION

According to EN60601-1, BELMONT PHOT-X II MODEL 303 is classified as follows.

- a. Protection against electric shock : Class I Equipment, Type B Applied Parts
- b. Protection against ingress of water : Ordinary
- c. Mode of operation : Intermittent Operation (Duty Cycle = 1 : 50)
- d. Equipment not suitable for use in the presence of a flammable anesthetic mixture with air or with oxygen or nitrous oxide.

5. SYMBOL

In this book, on the labels or on the control panel of PHOT-X II MODEL 303, following symbols are used. Confirm the meaning of each symbol.

	Consult written Instructions in Manuals		Protection against electric shock : Type B		ON (POWER)		OFF (POWER)
	Protection Grounding		Exposure Switch		X-ray Emission		Ready
	Upper Incisor		Upper Cuspid & Pre Molar		Upper Molar		Occlusal
	Lower Incisor		Lower Cuspid & Pre Molar		Lower Molar & Bite Wing		Bite Wing
	Digital Imaging		Child Patient		Adult Patient		Large Patient
	Regular Cone		Long Cone				

[2] MAJOR COMPONENTS

1. FOOR MOUNT TYPE (FK1/FK2)

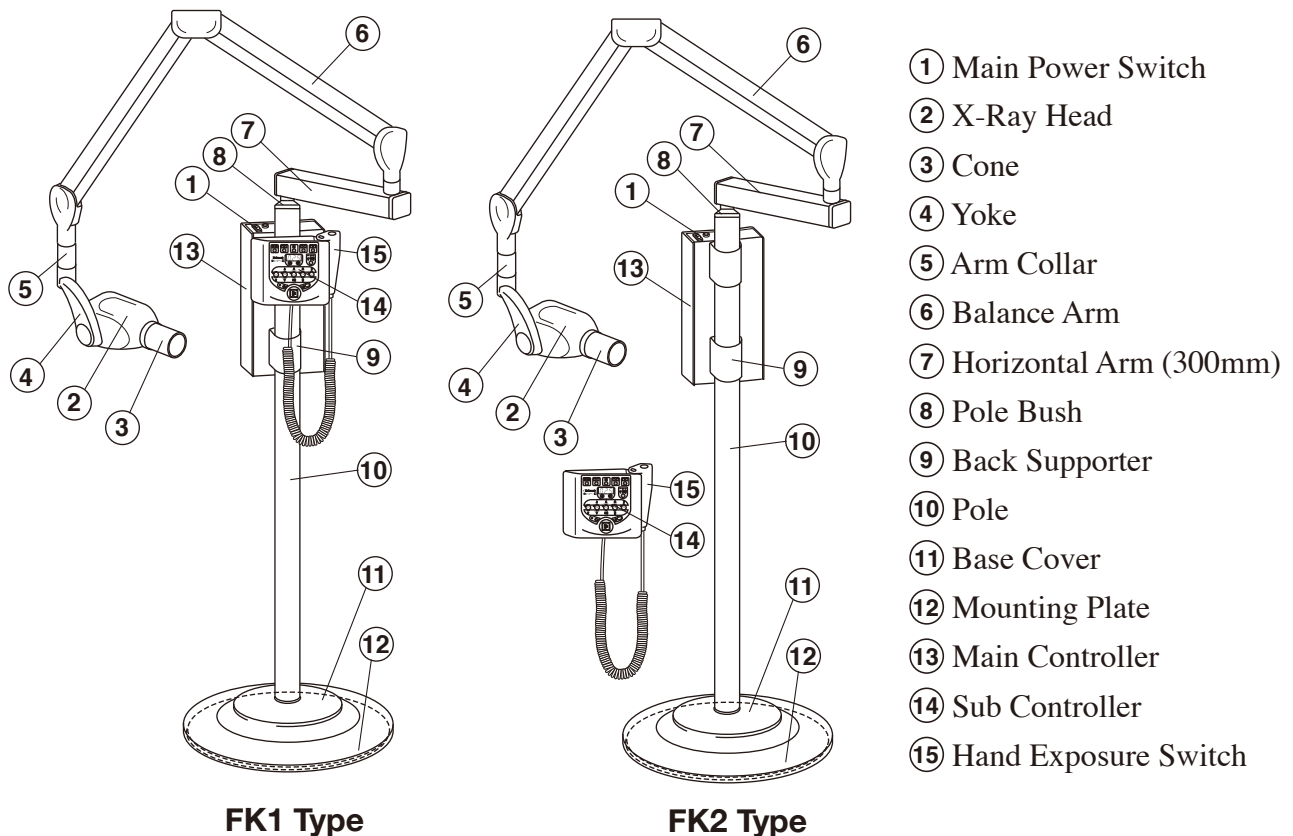

Fig.2-1 Major Components for FK1/FK2

2. MOBILE TYPE (FM)

- ① Main Power Switch
- ② X-Ray Head
- ③ Cone
- ④ Yoke
- ⑤ Arm Collar
- ⑥ Balance Arm
- ⑦ Pole Bush
- ⑧ Pole
- ⑨ Pole Base
- ⑩ Leg Bar (long)
- ⑪ Leg Bar (Short)
- ⑫ Lock Caster
- ⑬ Standard Caster
- ⑭ Main Controller
- ⑮ Sub Controller
- ⑯ Hand Exposure Switch

⚠ CAUTION

When moving mobile type (FM) x-ray on the floor, close the balance arm and keep holding the balance arm.

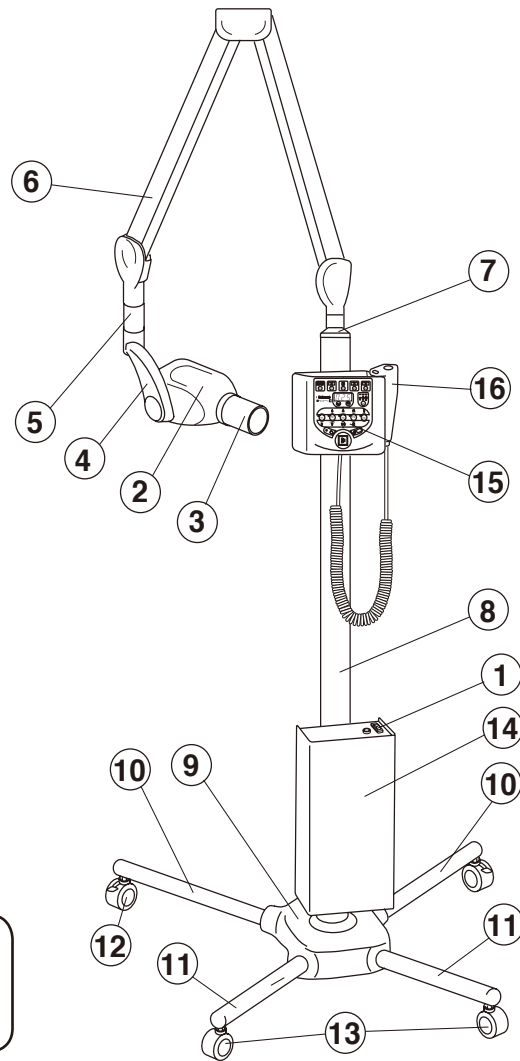
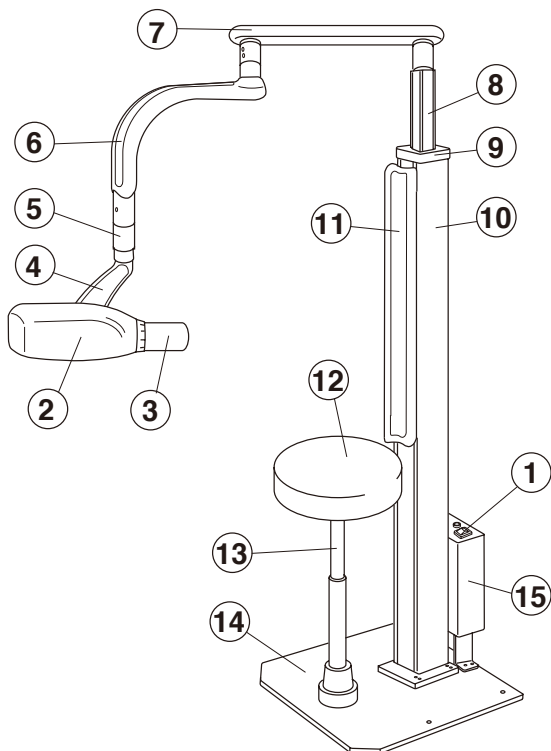

Fig.2-2 Major Components for FM

3. ROOM MOUNT TYPE (RK)



- ① Main Power Switch
- ② X-Ray Head
- ③ Cone
- ④ Yoke
- ⑤ Arm Collar
- ⑥ Swing Arm 1
- ⑦ Swing Arm 2
- ⑧ Sliding Post
- ⑨ Column Cover
- ⑩ Colum
- ⑪ Backrest Cushion
- ⑫ Seat
- ⑬ Gas Pump
- ⑭ Base Plate
- ⑮ Main Controller
- ⑯ Sub Controller
- ⑰ Hand Exposure Switch (Option)

Fig.2-3 Major Components for RK

4. WALL MOUNT TYPE (WK)

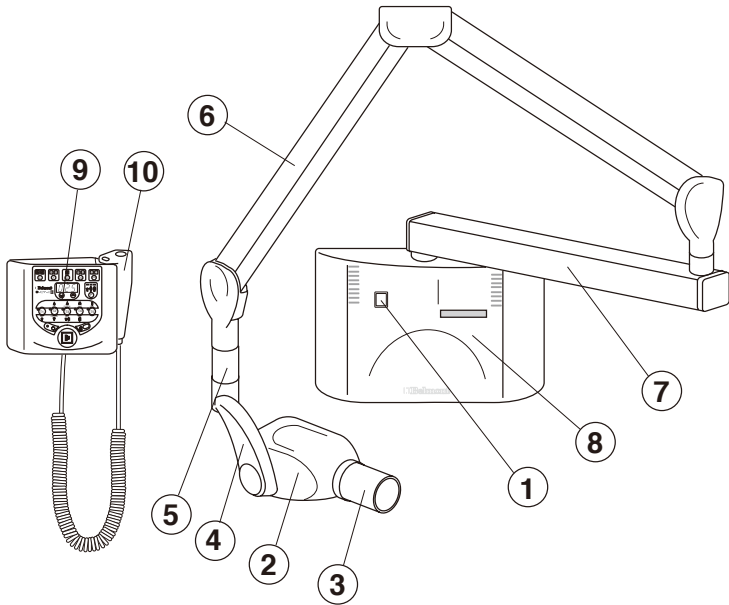

- ① Main Power Switch
- ② X-Ray Head
- ③ Cone
- ④ Yoke
- ⑤ Arm Collar
- ⑥ Balance Arm
- ⑦ Horizontal Arm
- ⑧ Main Controller
- ⑨ Sub Controller
- ⑩ Hand Exposure Switch (Option)

Fig.2-4 Major Components for WK

5. CEILING MOUNT TYPE (CK)

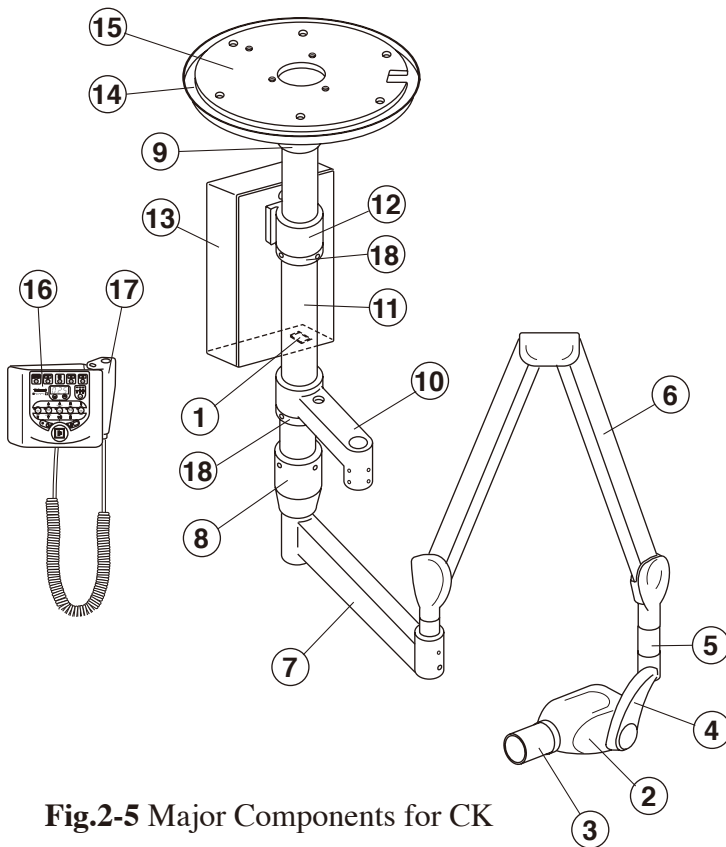

- ① Main Power Switch
- ② X-Ray Head
- ③ Cone
- ④ Yoke
- ⑤ Arm Collar
- ⑥ Balance Arm
- ⑦ Swing Arm
- ⑧ Swing Post
- ⑨ Cover Ring
- ⑩ Light Arm (Option)
- ⑪ Ceiling Pole
- ⑫ Main Controller Bracket
- ⑬ Main Controller
- ⑭ Ceiling Cover
- ⑮ Ceiling Mounting Plate
- ⑯ Sub Controller
- ⑰ Hand Exposure Switch (Option)
- ⑱ Support Ring

Fig.2-5 Major Components for CK

6. SUB CONTROLLER

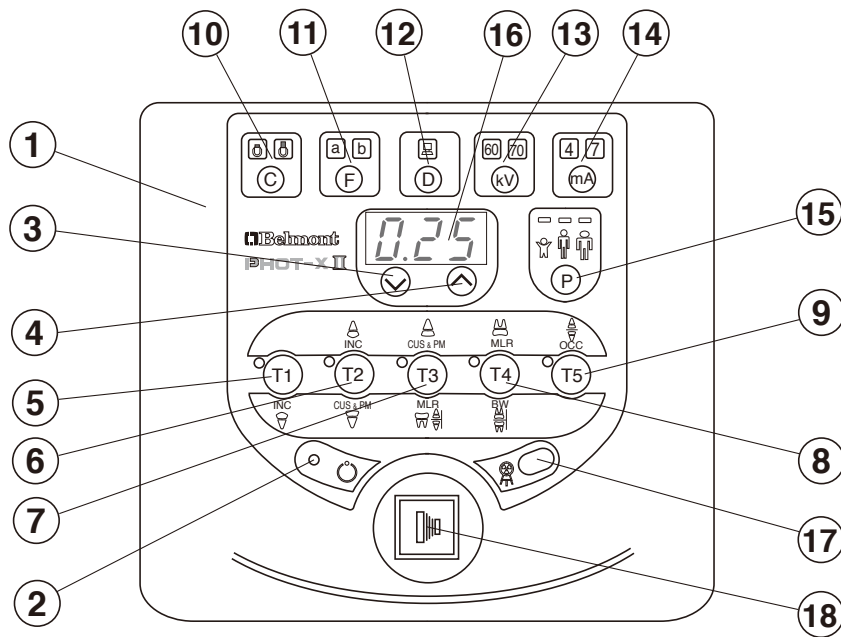

Fig.2-6 Sub Controller Switches

- | | |
|---|---------------------------------|
| ① Sub Controller Front Panel | ⑩ Cone Type Selection Switch |
| ② Ready Light | ⑪ Film Speed Selection Switch |
| ③ Exposure Time Adjusting Switch (Down) | ⑫ Digital Imaging Switch |
| ④ Exposure Time Adjusting Switch (Up) | ⑬ kV Selection Switch |
| ⑤ Tooth Selection Switch (T1) | ⑭ mA Selection Switch |
| ⑥ Tooth Selection Switch (T2) | ⑮ Patient Size Selection Switch |
| ⑦ Tooth Selection Switch (T3) | ⑯ Exposure Time Display Window |
| ⑧ Tooth Selection Switch (T4) | ⑰ Exposure Warning Light |
| ⑨ Tooth Selection Switch (T5) | ⑱ Exposure Switch |

[3] FUNCTION OF CONTROLS

① Main Power Switch (Fig.2-1 ~ Fig.2-5)

Pushing the upper side of this switch to the ON position energizes the x-ray unit. (Ready light and pre-select lights for cone type, film or digital, kV, mA, and patient size illuminate.)

It is recommended to keep this switch OFF when the unit is not in use, in order to prevent an accidental exposure.

IMPORTANT : To prevent the risk of an accidental exposure, push the lower side of this switch to the OFF position, when the unit is not in use.

② Ready Light (Fig.2-6)

This light illuminates when the line voltage is within operable range (108 ~ 132Vac).

When this light is not on, exposure can not be made.

③ ④ Exposure Time Adjusting Switches (Fig.2-6)

By momentarily pushing the $\text{\textcircled{^}}$ (or $\text{\textcircled{v}}$) switch, the exposure time displayed increases (or decreases) by one increment. By keeping the switch depressed more 2 sec., the exposure time displayed increases (or decreases) continuously until the switch is released.

Model 303 has the following 24 exposure time settings :

0.00, 0.01, 0.02, 0.03, 0.04, 0.05, 0.06, 0.08, 0.10, 0.13, 0.16, 0.20, 0.25, 0.32, 0.40
0.50, 0.63, 0.80, 1.00, 1.25, 1.60, 2.00, 2.50, 3.20 (sec.)

⑤ ~ ⑨ Tooth Selection Switches (T1 ~ T5) (Fig.2-6)

Pushing one of these switches sets the exposure time automatically for the following ⑩ ~ ⑮.

⑤ T1 : Incisor of Mandible

⑥ T2 : Incisor of Maxilla, Cuspid & Premolar of Mandible

⑦ T3 : Cuspid & Premolar of Maxilla, Molars of Mandible, Bitewing

⑧ T4 : Molar of Maxilla, Bitewing Molars

⑨ T5 : Occlusal

If the T1 switch ⑤ is depressed more than 3 sec. unit goes into “ Lock Mode”. In lock mode, the only functional switch is the power switch. To exit from the lock mode, depress the T1 switch more than 3 sec. again.

⑩ Cone Type Selection Switch (Fig.2-6)

Depressing this switch for more than 2 sec. selects the cone type : 8” standard cone or 12” optional long cone. (If the optional rectangular cone is to be used, select the 8” standard cone setting.)

⑪ Film Speed Selection Switch (Fig.2-6)

a. PHOT-X II has 16 film speed settings. (F.00 ~ F.15)

Two speed settings are pre-set at the factory (a & b) and can be selected with switch ⑮.

a = Film speed No. F.09 (equivalent to ISO speed group “ D”, or Kodak Ultra-Speed film)

b = Film speed No. F.05 (equivalent to ISO speed group “ F/E”, or Kodak InSight film)

b. Pushing this switch momentarily displays the selected film speed setting in the **Exposure Time Display Window** ⑮.

Depressing this switch for more than 2 sec. changes the film type being selected.

c. If the **Digital Imaging Switch** (12) is depressed, both of the film speed indicating lights (a & b) are turned off.

(12) Digital Imaging Switch (Fig.2-6)

If a digital imaging system is used, shorter exposure time is often required. PHOT-X II has 16 speeds for digital imaging (d.00 ~ d.15). Pushing this switch momentarily displays the speed being selected in the **Exposure Time Display Window** (16). With the factory speed setting d.06, the exposure time becomes half of F.06 setting.

TABLE 1. Speed Setting and Exposure Time (Regular Cone) [unit : sec.]

Speed Setting	kV	mA	Child					Adult					Large Adult					
			T1	T2	T3	T4	T5	T1	T2	T3	T4	T5	T1	T2	T3	T4	T5	
F.09	60	4	0.16	0.16	0.20	0.25	0.32	0.25	0.32	0.32	0.40	0.63	0.32	0.40	0.40	0.50	0.80	
		7	0.08	0.10	0.13	0.13	0.20	0.13	0.16	0.20	0.25	0.32	0.16	0.20	0.25	0.32	0.40	
	70	4	0.10	0.13	0.16	0.16	0.25	0.16	0.20	0.25	0.32	0.40	0.20	0.25	0.32	0.40	0.50	
		7	0.06	0.08	0.08	0.10	0.16	0.10	0.13	0.16	0.16	0.25	0.13	0.16	0.20	0.20	0.32	
F.05	60	4	0.06	0.08	0.08	0.10	0.16	0.10	0.13	0.16	0.16	0.25	0.13	0.16	0.20	0.20	0.32	
		7	0.03	0.04	0.05	0.06	0.08	0.06	0.06	0.08	0.10	0.13	0.08	0.08	0.10	0.13	0.16	
	70	4	0.04	0.05	0.06	0.08	0.10	0.08	0.08	0.10	0.13	0.16	0.10	0.10	0.13	0.16	0.20	
		7	0.02	0.03	0.04	0.04	0.06	0.04	0.05	0.06	0.06	0.10	0.05	0.06	0.08	0.08	0.13	
	d.06	60	4	0.04	0.05	0.05	0.06	0.10	0.06	0.08	0.10	0.10	0.16	0.08	0.10	0.10	0.13	0.20
			7	0.02	0.03	0.03	0.04	0.10	0.04	0.04	0.05	0.06	0.08	0.05	0.05	0.06	0.08	0.10
70		4	0.03	0.03	0.04	0.04	0.06	0.05	0.05	0.06	0.06	0.10	0.06	0.06	0.08	0.10	0.13	
		7	0.02	0.02	0.02	0.03	0.04	0.03	0.03	0.04	0.04	0.06	0.03	0.04	0.05	0.05	0.08	

TABLE 2. Speed Setting and Exposure Time (Long Cone) [unit : sec.]

Speed Setting	kV	mA	Child					Adult					Large Adult				
			T1	T2	T3	T4	T5	T1	T2	T3	T4	T5	T1	T2	T3	T4	T5
F.09	60	4	0.40	0.50	0.63	0.63	1.00	0.63	0.80	1.00	1.00	1.60	0.80	1.00	1.25	1.25	2.00
		7	0.25	0.25	0.32	0.40	0.50	0.40	0.50	0.50	0.63	1.00	0.50	0.63	0.63	0.80	1.25
	70	4	0.32	0.32	0.40	0.50	0.63	0.50	0.63	0.63	0.80	1.25	0.63	0.80	0.80	1.00	1.60
		7	0.16	0.20	0.25	0.25	0.40	0.25	0.32	0.40	0.50	0.63	0.32	0.40	0.50	0.50	0.80
F.05	60	4	0.16	0.20	0.25	0.25	0.40	0.25	0.32	0.40	0.50	0.63	0.32	0.40	0.50	0.63	0.80
		7	0.10	0.10	0.13	0.16	0.25	0.16	0.20	0.25	0.25	0.40	0.20	0.25	0.25	0.32	0.50
	70	4	0.13	0.13	0.16	0.20	0.25	0.20	0.25	0.25	0.32	0.50	0.25	0.32	0.32	0.40	0.63
		7	0.06	0.08	0.10	0.10	0.16	0.10	0.13	0.16	0.20	0.25	0.13	0.16	0.20	0.25	0.32
d.06	60	4	0.10	0.13	0.16	0.16	0.25	0.16	0.20	0.25	0.25	0.40	0.20	0.25	0.32	0.32	0.50
		7	0.06	0.08	0.08	0.10	0.13	0.10	0.13	0.13	0.16	0.25	0.13	0.16	0.16	0.20	0.32
	70	4	0.08	0.08	0.10	0.13	0.16	0.13	0.16	0.16	0.20	0.32	0.16	0.20	0.20	0.25	0.40
		7	0.04	0.05	0.06	0.06	0.10	0.06	0.08	0.10	0.13	0.16	0.08	0.10	0.13	0.13	0.20

(13) kV Selection Switch (Fig.2-6)

Momentarily depressing this switch will change the tube potential to 60 or 70 kV. Since the tube potential is constant DC, a 60 kV setting the PHOT-X II is similar to a 70 kVp setting on a conventional x-ray. If either the **Film Speed Switch** (11) or **Digital Imaging Switch** (12) is depressed, 60kV is automatically selected.

(14) mA Selection Switch (Fig.2-6)

Momentarily depressing this switch will change the tube current setting (4 or 7 mA). If the **Digital Imaging Switch** (12) is depressed, 4 mA is automatically selected and if the **Film Speed Switch** (11) is depressed, 7 mA is automatically selected,

(15) Patient Size Selection Switch (Fig.2-6)

This switch alters the selection of patient type/size to be radiographed (child → adult → large → child) and sets the exposure time automatically.

NOTE : Setting or adjusting the exposure time manually (with ^ or v switch) supersedes (5) ~ (15) functions.

⑩ Exposure Time Display Window (Fig.2-6)

This window displays the selected exposure time. If an abnormal condition exists or a malfunction occurs, an Error Code is displayed. (See Section : [9] **ERROR CODES**)

⑪ Exposure Warning Light (Fig.2-6)

Illumination of this light indicates the unit is producing x-radiation.

⑫ Exposure Switch (Fig.2-6)

This switch initiates radiographic exposure. When making an exposure, depress and hold this switch until the **Exposure Warning Light ⑪** and the audible warning shut off. Failure to keep this switch depressed will result in the premature termination of the exposure and an error code E.00 will be displayed in **Exposure Time Display Window ⑩**.

[4] OPERATING PROCEDURES

1. Turn ON the Main Power Switch ①.
2. Confirm that Ready Light ② is illuminated.

NOTE : The ready light will not illuminate unless the incoming line voltage is correct and within the x-ray's operable range.

3. Select the appropriate tooth type (⑤ ~ ⑨), and confirm the pre-selected conditions (cone type, film or digital, kV, mA and patient size) are suitable for exposure.

NOTE : To manually set the exposure time, depress either of the manual Exposure Time Adjusting Switches (^ or v) until the desired exposure time appears in the Exposure Time Display Window ⑩. While the unit is in manual mode, other selection switches (⑤ ~ ⑮) do not affect exposure time. (All of the tooth selection lights are off.) To return to the automatic exposure time selection mode, depress any one of Tooth Selection Switches (⑤ ~ ⑨).

4. Depress the Exposure Switch ⑫. When the Exposure Switch is depressed, the Exposure Warning Light ⑪ illuminates and the audible warning sounds. Do not release the Exposure Switch until the Exposure Warning Light and audible warning automatically shut off. Failure to keep the switch depressed will result in exposure being terminated prematurely.
5. To continue to radiograph other teeth, just select appropriate Tooth Selection Switches (⑤ ~ ⑨).

IMPORTANT : To protect x-ray tubehead from heat accumulation, wait for a time interval that is equal to 50 times the selected exposure time before making additional exposures. (Example : a 25 sec. wait is necessary between exposures that are 0.5 sec. in duration.)

6. Turn OFF the Main Power Switch ① in order to prevent accidental exposures when the unit is not in use.

NOTE : If the unit left over 8 min. without being operated and the Main Power Switch ① is kept on, figure " 1 " runs through the Exposure Time Display Window ⑩. This does not mean that malfunction of the unit has occurred ; this is an energy saving feature. The unit returns to ready condition by pressing any one of the switches, except the Exposure Switch ⑫.

[5] HAND EXPOSURE SWITCH

Hand exposure switch can be connected to the sub controller. Since this exposure switch has a coiled cord, operators can stand in the most suitable position for operation.

As controller has separate connector for this exposure switch, both exposure switch (18) on the front panel of sub controller and this hand exposure switch can be used.

If local code prohibits use of both, ask installer to disconnect the connector of either switch.

[6] DIGITAL IMAGING SYSTEM

If electrical instruments such as a digital imaging system is used with PHOT-X II MODEL 303 x-ray, the following points should be confirmed to keep electrical safety.

CAUTION

The use of ACCESSORY equipment not complying with the equivalent safety requirements of PHOT-X II MODEL 303 may lead to a reduced level of safety of the resulting system.

Consideration relating to the choice shall include :

- **use of the accessory in the PATIENT VICINITY**
- **evidence that the safety certification of the ACCESSORY has been performed in accordance to the appropriate EN60601-1 and/or EN60601-1 harmonized national standard.**

[7] CLEANING AND DISINFECTION

In order to ensure proper hygiene and cleaning of the equipment, the following procedures must be followed :

WARNING

Before cleaning the unit, turn off the main power switch and breaker on the branch line. This is required because some internal parts remain connected to main voltage even when the main power switch has been turned off.

Wipe the outside surface with a paper towel dampened with a disinfectant solution or household, non abrasive cleaner. DO NOT SPRAY SOLVENT OR LIQUID DIRECTLY ON THE X-RAY UNIT. BE CAREFUL NOT TO ALLOW SOLVENTS TO RUN OR DRIP into the PHOT-X II. This could cause damage to the PHOT-X II. Allow surfaces to air dry before tuning breaker and main switch back on.

Parts in contact with skin :

To ensure proper cleaning of these parts, periodic disinfection with a non corrosive surface disinfectant is recommended.

[8] DISPOSAL OF USED FILM AND CCD COVERS

Dispose of used film covers and CCD sensor covers appropriately, according to the procedures indicated by each manufacturer and by local codes.

[9] ERROR CODES

If an abnormal condition exists in the unit, or a malfunction occurs, an error code is displayed in the Exposure Time Display Window (16). Please refer to the Table below.

Error Code	Condition	Step to be Taken	Possible Solution
E.00	Exposure switch was released before exposure termination.	All the tooth selection lights blink. Depress one of the tooth switches.	Release the exposure switch after the exposure lamp turns off.
E.01	Exposure switch was depressed within 10 sec. of previous exposure.	A 10 sec. delay is built in between each exposure. Release the exposure switch.	There should be a "wait" interval of 50 times the exposure time between successive exposure.
	Exposure time was set and exposure switch was depressed within 3 sec. of the power switch being turned on.		Wait a minimum 3 sec. after the main power switch is turned on before pressing the exposure switch.
E.02	Line voltage was less than 90% of rated voltage.		Confirm that ready lamp is on before exposure. Ask service personnel to check the line voltage.
E.03	Line voltage was more than 110% of rated voltage.		
E.05	Tube current at last portion of exposure was less than 3 mA at 4 mA setting or less than 5.25 mA at 7 mA setting	Turn off the main power switch and wait for approximately 2 min. Turn on the main power switch again.	If same error code is displayed, call service personnel.
E.06	Tube current at last portion of exposure was more than 5 mA at 4 mA setting or more than 8.75 mA at 7 mA setting		
E.07	During the exposure, tube current becomes less than 2 mA at 4mA setting or less than 3.5 mA at 7 mA setting.		
E.08	During the exposure, tube current becomes more than 15mA.		
E.09	Setting for pre-heating time is out of range.		
E.10	Exposure switch or exposure circuit had been ON, when main power switch is turned on.		
E.11	Tube current is detected during pre-heating period.		
E.12	Tube current is detected when main power switch is turned on.		
E.14	Tube potential at last portion of exposure was less than 50 kV at 60 kV setting or less than 60 kV at 70 kV setting.		

Error Code	Condition	Step to be Taken	Possible Solution
E.15	Tube Potential at last portion of exposure was more than 70 kV at 60 kV setting.	Turn off the main power switch and wait for approximately 2 min. Turn on the main power switch again.	If same error code is displayed, call service personnel.
E.16	During the exposure, tube potential becomes less than 40 kV at 60 kV setting or less than 50 kV at 70 kV setting.		
E.17	During the exposure, tube potential becomes more than 80 kV.		
E.19	Excess current was detected in primary circuit of high voltage transformer.		
E.20	Exposure switch was depressed when tube head temperature was over 60°C.	Release the exposure switch,	
E.22	Failure of electrical communication between the power PCB and timer PCB.	Turn off the main power switch and turn on again.	
E.23	Some switch had been on, when the main power switch is turned on. (Except the exposure switch.)		

[10] MAINTENANCE

PHOT-X II MODEL 303 x-ray unit requires post installation confirmation and periodic maintenance checks to be performed by dealer service personnel. These procedures ensure that the x-ray unit is functioning within the manufacture's specifications and remains in compliance with the Standard.

It is responsibility of the owner of the unit to see that these maintenance checks are done **once every 6 months** and that they are performed by a trained, certified service technician.

The specific instructions to perform these checks are located within the PHOT-X II MODEL 303 Installation Manual.

A. Line voltage confirmation

B. Tube potential and Tube current confirmation

C. Inspection of arm and head movement

D. Mechanical safety

1. The floor mounting plate (FK1/FK2) or base plate (RK) should be checked to confirm that it is securely attached to the floor.
2. The arm mounting bracket should be checked to confirm that it is securely attached to the wall. The arm mounting bracket must be level horizontally and vertically (WK).
3. Check and verify that the horizontal arm is not raising up and out of the arm mounting bracket or pole bushing. This should be verified routinely by treatment room personnel.

[11] TECHNICAL DATA

1. X-ray tube ----- Toshiba D-0711 (Stationary Anode)
 - a. Focal spot ----- 0.7 mm
 - b. Target Material ----- Tungsten
 - c. Target angle ----- 16°
 - d. Maximum anode heat content ----- 7kJ (10kHU)
2. Maximum x-ray tube assembly heat content ----- 120kJ (170kHU)
3. Rated peak tube potential ----- 60 kV / 70 kV selectable
4. Rated tube current ----- 4 mA / 7 mA selectable
5. Maximum rated peak tube potential ----- 70 kV
6. Electrical ratings
 - a. Rated Line Voltage ----- 230 Vac
 - b. Minimum Line Voltage ----- 207 Vac
 - c. Maximum Line Voltage ----- 253 Vac
 - d. Rated Line Power ----- 1.5 kVA
 - e. Rated Line Current at 70kV,7mA ----- 6.6 Aac
 - f. Maximum Line Current at 70kV,7mA ----- 7.3 Aac
(Internal Resistance ----- 1.02 Ω max.)
 - g. Range of Line Voltage Regulation ----- 0 ~ 3 %
7. Power line frequency ----- 50Hz,Single Phase
8. Exposure time ----- 0.01 ~ 3.2 sec.
9. Inherent filtration ----- 1.7 mm Al Equivalent
10. Added filtration ----- 0.3 mm Al
11. Minimum filtration permanently in useful beam ----- 2.0 mm Al Equivalent at 70 kV
12. Nominal roentgen output

	60 kV		70 kV	
	4 mA	7 mA	4 mA	7mA
a. Distal end of regular cone -----	5.4	9.4	7.1	12.4 mGy/sec. ± 40%
b. Distal end of long cone -----	2.4	4.2	3.1	5.5 mGy/sec. ± 40%

(Data obtained by direct measurement in the useful beam)
13. Nominal electrical output of H.V. generator ----- 0.49 kW at 70 kV, 7 mA
14. Cone

	Source to skin distance	Field size
a. Regular cone -----	203 mm	58 mm dia., circular
b. Long cone (option) -----	305 mm	58 mm dia., circular
c. Rectangular cone (option) -----	203 mm	36 x 47 mm, rectangular
15. Maximum symmetrical radiation field ----- 60 mm dia. at distal end of cone

16. Leaking technique factor----- 70 kV / 0.14 mA
(0.14 mA is maximum rated continuous current for 7 mA with a duty cycle 1 : 50)
17. Duty cycle ----- 1 : 50 (0.5 sec. exposure with 25 sec. interval)
18. Maximum deviation of tube potential, tube current and exposure time
- a. Below 0.1 sec. setting----- ± 10 kV, ± 2 mA, ± 5 msec.
 - b. 0.1 sec. setting & up----- ± 5 kV, ± 1 mA, ± 10 msec.
19. Measurement base of technique factors
- a. peak tube potential----- Average of peak tube potentials during one exposure
 - b. tube current----- Average of tube current during one exposure
 - c. exposure time----- Time period during x-ray is emitted
20. Half value layer ----- 1.5 mm Al over
21. Source to the base of cone distance ----- 94 mm
22. Environmental condition for storage----- $-20 \sim 70^{\circ}\text{C}$, $10 \sim 100\%$, $500 \sim 1060\text{hPa}$
23. Environmental condition for operation ----- $10 \sim 40^{\circ}\text{C}$, $30 \sim 70\%$, $700 \sim 1060\text{hPa}$

[12] ELECTROMAGNETIC COMPATIBILITY(EMC)

Medical electrical equipment needs special precautions regarding EMC and needs to be installed and put into service according to the EMC information provided in this manual.

Portable and mobile RF communications equipment can affect medical electrical equipment. The equipment or system should not be used adjacent to or stacked with other equipment. If adjacent or stacked use is necessary, the equipment or system should be observed to verify normal operation in the configuration in which it will be used.

Guidance and manufacture's declaration – electromagnetic emissions		
The PHOT-XII model 303 x-ray is intended for use in the electromagnetic environment specified below. The customer or the user of the PHOT-XII model 303 x-ray should assure that it is used in such an environment.		
Emissions test	Compliance	Electromagnetic environment - guidance
RF emissions CISPR 11	Group 1	The PHOT-XII model 303 x-ray uses RF energy only for its internal function. Therefore, its RF emissions are very low and are not likely to cause any interference in nearby electronic equipment.
RF emissions CISPR 11	Class A	The PHOT-XII model 303 x-ray is suitable for use in all establishments other than domestic and those directly connected to the public low-voltage power supply network that supplies buildings used for domestic purposes.
Harmonic emissions IEC 61000-3-2	Class A	
Voltage fluctuations/ Flicker emissions IEC 61000-3-3	Complies	

Guidance and manufacture's declaration – electromagnetic immunity			
The PHOT-XII model 303 x-ray is intended for use in the electromagnetic environment specified below. The customer or the user of the PHOT-XII model 303 x-ray should assure that it is used in such an environment.			
Immunity test	IEC 60601 test level	Compliance level	Electromagnetic environment - guidance
Electrostatic discharge (ESD) IEC 61000-4-2	±6 kV contact ±8 kV air	±6 kV contact ±8 kV air	Floors should be wood, concrete or ceramic tile. If floors are covered with synthetic material, the relative humidity should be at least 30%.
Electrical fast transient/burst IEC 61000-4-4	±2 kV for power supply lines ±1 kV for input/output lines	±2 kV for power supply lines ±1 kV for input/output lines	Mains power quality should be that of a typical commercial or hospital environment.
Surge IEC 61000-4-5	±1 kV differential mode ±2 kV common mode	±1 kV differential mode ±2 kV common mode	Mains power quality should be that of a typical commercial or hospital environment.
Voltage dips, short interruptions and voltage variations on power supply input lines IEC 61000-4-11	<5% U_T (>95% dip in U_T) for 0.5 cycle 40% U_T (60% dip in U_T) for 5 cycle 70% U_T (30% dip in U_T) for 25cycle <5% U_T (>95% dip in U_T) for 5 s	<5% U_T (>95% dip in U_T) for 0.5 cycle 40% U_T (60% dip in U_T) for 5 cycle 70% U_T (30% dip in U_T) for 25cycle <5% U_T (>95% dip in U_T) for 5 s	Mains power quality should be that of a typical commercial or hospital environment. If the user of the PHOT-XII model 303 x-ray requires continued operation during power mains interruptions, it is recommended that the PHOT-XII model 303 x-ray be powered from an uninterruptible power supply or a battery.
Power frequency (50/60 Hz) magnetic field IEC 61000-4-8	3 A/m	0.3 A/m	Power frequency magnetic fields should be at levels characteristic of a typical location in a typical commercial or hospital environment.
NOTE U_T is the a.c. mains voltage prior to applications of the test level.			

Guidance and manufacture's declaration – electromagnetic immunity

The PHOT-XII model 303 x-ray is intended for use in the electromagnetic environment specified below. The customer or the user of the PHOT-XII model 303 x-ray should assure that it is used in such an environment.

Immunity test	IEC 60601 test level	Compliance level	Electromagnetic environment - guidance
Conducted RF IEC 61000-4-6	3 Vrms 150 kHz to 80 MHz outside ISM bands ^a	3 Vrms	<p>Portable and mobile RF communications equipment should be used no closer to any part of the PHOT-XII model 303 x-ray, including cables, than the recommended separation distance calculated from the equation applications to the Frequency of the transmitter.</p> <p>Recommended separation distance $d = 1.2\sqrt{P}$</p>
Radiated RF IEC 61000-4-3	3V/m 80 MHz to 2.5 GHz	3 V/m	<p>$d = 1.2\sqrt{P}$ 80 MHz to 800 MHz $d = 2.3\sqrt{P}$ 800 MHz to 2.5 GHz</p> <p>Where P is the maximum output power rating of the transmitter in watts (W) according to the transmitter manufacturer and d is the recommended separation distance in metres (m).</p> <p>Field strengths from fixed RF transmitters, as determined by an electromagnetic site survey,^a should be less than the compliance level in each frequency range.^b</p> <p>Interference may occur in the vicinity of equipment marked with the following symbol:</p> 

NOTE 1 At 80 MHz and 800MHz, the higher frequency range applies.

NOTE 2 These guidelines may not apply in all situations. Electromagnetic propagation is affected by adsorption and reflection from structures, objects and people.

- a Field strengths from fixed transmitters, such as base stations for radio (cellular/cordless) telephones and land mobile radios, amateur radio, AM and FM radio broadcast and TV broadcast cannot be predicted theoretically with accuracy. To assess the electromagnetic environment due to fixed RF transmitters, an electromagnetic site survey should be considered. If the measured field strength in the location in which the PHOT-XII model 303 x-ray is used exceeds the applicable RF compliance level above, the PHOT-XII model 303 x-ray should be observed to verify normal operation. If abnormal performance is observed, additional measures may be necessary, such as reorienting or relocating the PHOT-XII model 303 x-ray.
- b Over the frequency range 150 kHz to 80 MHz, field strengths should be less than 3V/m.

**Recommended separation distances between
Portable and mobile RF communications equipment and the PHOT-XII model 303 x-ray**

The PHOT-XII model 303 x-ray is intended for use in an electromagnetic environment in which radiated RF disturbances are controlled. The customer or the user of the PHOT-XII model 303 x-ray can help prevent electromagnetic interference by maintaining a minimum distance between portable and mobile RF communications equipment (transmitters) and the PHOT-XII model 303 x-ray as recommended below, according to the maximum output power of the communications equipment.

Rated maximum output power of transmitter W	Separation distance according to frequency of transmitter m		
	150 kHz to 80 MHz $d = 1.2\sqrt{P}$	80 MHz to 800 MHz $d = 1.2\sqrt{P}$	800 MHz to 2.5 GHz $d = 2.3\sqrt{P}$
0.01	0.12	0.12	0.23
0.1	0.38	0.38	0.73
1	1.2	1.2	2.3
10	3.8	3.8	7.3
100	12	12	23

For transmitters rated at a maximum output power not listed above, the recommended separation distance d in metres (m) can be estimated using the equation applicable to the frequency of the transmitter, where P is the maximum output power rating of the transmitter in watts (W) according to the transmitter manufacturer.

NOTE 1 At 80 MHz and 800MHz, the separation distance for the higher frequency range applies.

NOTE 2 These guidelines may not apply in all situations. Electromagnetic propagation is affected by adsorption and reflection from structures, objects and people.

NOTE

Representative in EU:
Takara Belmont (UK) Ltd.
Belmont House
One St.Andrews Way,Bow,
London E3 3PA U.K.
Tel: (44)20 7515 0333
Fax:(44)20 7987 3596



TAKARA BELMONT CORPORATION
1-1, 2-Chome, Higashi-shinsaibashi, Chuo-ku, Osaka, Japan
TEL. : (06) 6213-5945
TELEFAX : (06) 6212-3680

Book No. EDBA3
Printed in Japan 0608MA