

DENTAL CHAIR
PROGRES

**OPERATING
INSTRUCTIONS**

IMPORTANT

**This manual provides operating instructions for PROGRES.
The instructions contained in this booklet should be thoroughly read and understood before operating chair.
After the installation is completed, file this manual and refer back to it for future maintenance.**

 **Belmont**

















TABLE OF CONTENTS

Page

SAFETY PRECAUTIONS -----	1
1. OVERALL VIEW AND MAJOR PARTS -----	4
2. DIMENSIONS AND SPECIFICATIONS -----	5
3. OPERATING INSTRUCTIONS	
3-1. MAIN SWITCH -----	6
3-2. CONTROLS -----	6
3-3. SAFETY LOCK DEVICE -----	7
3-4. CHAIR ROTATION -----	7
3-5. HEADREST OPERATIONS -----	7
4. AUTO MODE POSITION ADJUSTMENTS -----	8
5. CARE AND MAINTENANCE -----	8
6. MAINTANANCE AND INSPECTION -----	9
7. BEFORE ASKING FOR REPAIRS -----	10
8. ELECTROMAGNETIC COMPATIBILITY(EMC)-----	11

SYMBOLS

Following symbols are used in this manual of PROGRES CHAIR. Confirm the meaning of each symbol.

LP	Chair last position	0	Chair auto return	1	Chair preset1	2	Chair preset2
	To raise the chair		To Recline the backrest		To lower the chair		To raise the backrest
	Chair manual control		Alternating current		Protective earth (ground)	SN	Serial number
	Non-ionizing radiation		Authorized representative in the European community		Manufacturer		Date of manufacture
	Caution It means "caution, warnings, or possibility to danger".		Separate collection for electrical and electronic equipment		Type B Applied Parts		Refer to instruction manual/booklet

Intended Use of the Product

This product is intended for the exclusive use for diagnoses, treatments and relative procedures of dentistry, and must be operated or handled by the qualified dentists or by dental staffs under the supervision of the dentist.

Such dentists or dental staffs should instruct and/or assist the patients to approach to and leave from the product.

Patients should not be allowed to operate or handle the product unless he/she is so instructed.

Environmental Requirements

Ambient Temperature	Operating +5 °C- +40 °C	Storage -10 °C- +50 °C
Humidity	10 % - 80%	
Atmospherical Pressure	600 hPa - 1060 hPa	

Important Notes

In case of the troubles, please contact Takara Belmont offices or your dealers.

Do not disassemble or attempt to repair.

Disassembly, repair or modifications should only be done by a qualified repair technician.

Attempts at disassembly, repair or modifications may lead to abnormal operation and accidents.



In case of disposal of equipment

When disposing the chair, appropriately dispose complying with all current applicable regulations and local codes.

In EU area, EU directive 2002/96/EC on waste electrical and electronic equipment (WEEE) is applied on this product. In this directive, environment conscious recycling/abandonment is obligated.

SAFETY PRECAUTIONS

- Before use, read the “Safety precautions” carefully to ensure proper use.
- The following information is designed to ensure safe use of this product and to prevent injury and damage to you and others. The precautions contained here are classified depending on the severity and degree of imminence of possible injury or damage resulting from improper use. Be sure to follow all the information, which is important for safety.

Classification of precautions	Severity and degree of imminence of possible injury or damage
 WARNING	This symbol indicates that “ignorance of these precautions may lead to severe injury or even death as a result of improper use.”
 CAUTION	This symbol indicates that “ignorance of these precautions may lead to mild or moderate physical injury or damage to property as a result of improper use.”
NOTICE	This symbol indicates that “it is recommended to follow these precautions for safety.”

WARNING

1. Be sure to turn off breakers for equipment in the clinic when this product will not be used for a long period of time

Be sure to turn off breakers for equipment in the clinic when this product will not be used for a long period of time (following the completion of work, during the suspension of business, etc.). Insulation degradation may cause electrical fire.

2. Be sure to turn off the main switch upon completion of work or during work breaks

Be sure to turn off the main switch upon completion of work or during work breaks. This prevents incorrect operation due to accidental contact and associated hazards.

3. Do not sit on other than seat

When the backrest is at the forward position, do not sit on or place an undue load on the headrest or legrest of dental chair. This could cause the unit to topple or could damage the unit.

4. Do not place an undue load on the arm

Do not get on or place an undue load on the dental chair armrest. This could cause the unit to topple or other accidents.

5. Connect to an appropriate power source

This equipment must be connected to an appropriate power source.

6. Be sure to establish a grounding connection

Be sure to establish a proper grounding connection. (Refer to a vendor for grounding connection.) Failure or electric leakage may lead to electric shock.

7. Never disassemble, repair or modify this product

Individuals other than certified repair technicians should not disassemble or attempt to repair and modify this product. This could lead to an accident, failure, electric shock or fire.

8. Use with caution in the presence of electromagnetic interference waves

Do not place this product around equipment generating electromagnetic waves (including communications equipment, elevators, etc.) as incorrect operation of this product may occur in the presence of electromagnetic interference waves. Do not use equipment generating electromagnetic waves, such as mobile phones, around this product.

SAFETY PRECAUTIONS

WARNING

9. Be sure to turn off the main switch when electrocautery is in use

Be sure to turn off the main switch when electrocautery is in use, because noise may cause incorrect operation of this product.

10. Ensure the maintenance of this product

- Failure to maintain this product may lead to physical injury or property damage.
- Refer to the section of maintenance.

11. Immediately wipe off any water spills or leakage on the floor

Immediately wipe off any water spills or leakage on the floor. Decreased strength of the floor may lead to physical injury including fall, or property damage.

12. Use with caution on patients with a cardiac pacemaker

Use this product with extreme caution on patients with a cardiac pacemaker. In the case of any abnormalities in patients during use, immediately turn off this product and discontinue use.

CAUTION

1. Only experienced personnel should use this product

Only dentists or other dental professionals should use this product.

2. Confirm safety before use.

Before use, confirm that the parts are correctly and safely operating and that there are no obstacles around this product.

3. Pay attention to patients and children

Keep your eyes on patients (especially, children) so that mischief or inadvertent operation of equipment will not lead to unexpected accidents.

4. Discontinue use if you feel that “something is wrong”

Always be careful to inspect this product for looseness, rattling, tilting, wobbling, sounds, temperature, odors, etc. Immediately discontinue use at the first feeling that “something is wrong.”

5. keep your eyes on the patient during operation.

- Confirm that the patient is seated in the proper position. Keep your eyes on the patient during the operation.
- Pay special attention to surroundings at automatic operation of the dental treatment table. Damage to the backrest, stool or Doctor's table may occur.

6. Do not smack or rub this product

Do not smack or rub this product forcefully. This could cause damage to covers or defective function.

7. Precautions for cleaning the resin cover

For cleaning, do not use cleaning agents containing solvent or abrasives, thinners or oil-based alcohol (butanol and isopropyl alcohol), which may cause cracks.

SAFETY PRECAUTIONS

CAUTION

8. Be sure to operate switches with your hands

Be sure to operate switches with your hands, except the foot controller, which is operated with your foot. Operation with body parts other than hands may cause damage or incorrect operation.

9. Pay attention during the headrest operation

Do not allow hands, fingers, or hair to become entangled in the moving parts of the headrest during operation.

10. Precautions for cleaning

- Never use sandpaper, metal scrub brushes and abrasive cleaning agents to clean the unit.
- Do not use strongly acidic cleaning agents or alkaline pipe cleaning agents to avoid corrosion of metals, etc.

11. Read the documents accompanying the various pieces of equipment

Before use, be sure to carefully read the package inserts and Instruction Manuals accompanying the various pieces of equipment (including optional articles) to ensure proper use.

NOTICE

1. Troubleshooting and contact information

In the case of any problems, discontinue use, turn off the main switch and contact the dealer or our company.

2. Handling of equipment in the case of a power failure

Put the handpiece in the holder and turn off the main switch if equipment stops working during use due to a power failure or other reasons.

1. OVERVIEW AND MAJOR PARTS

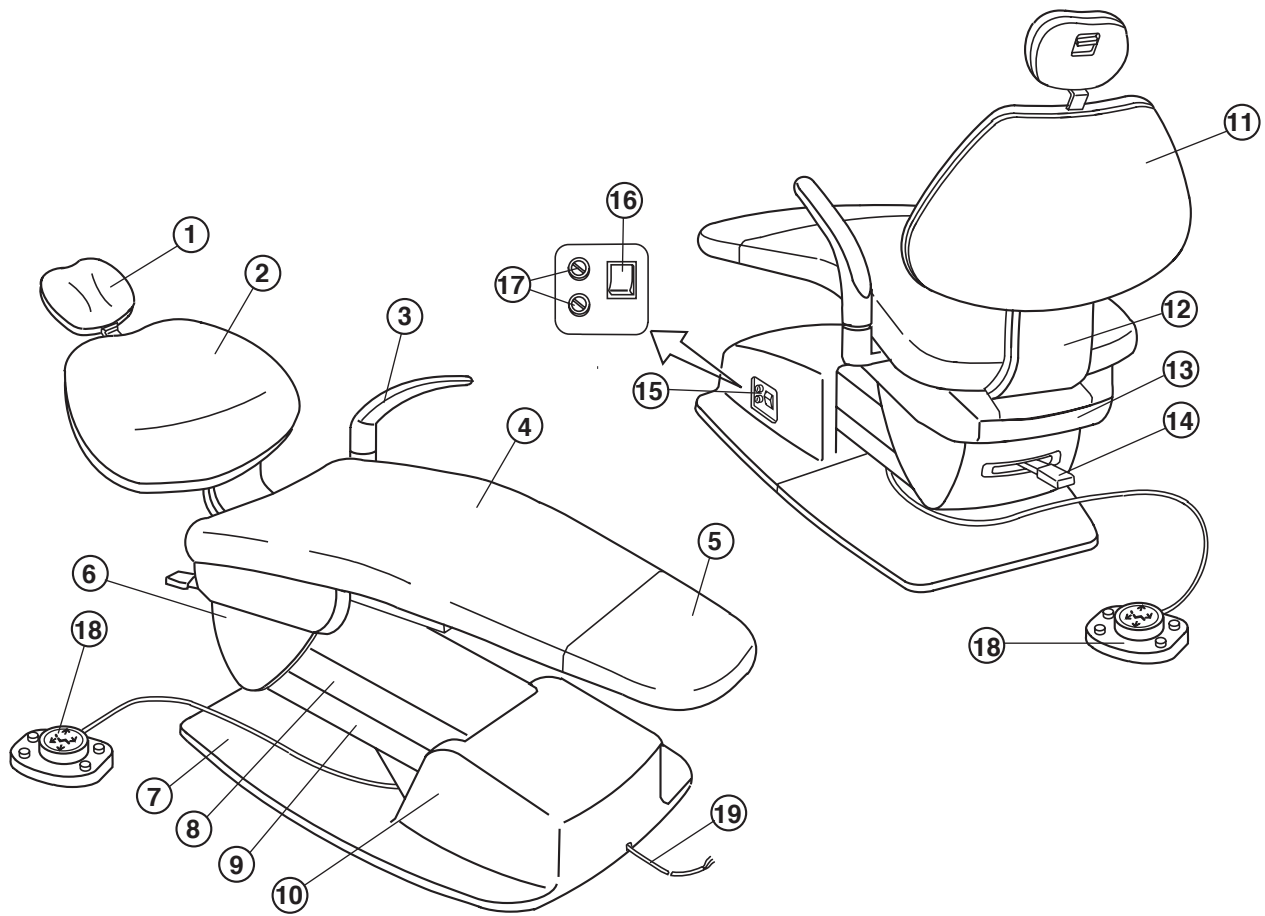

Fig.1-1 Overview

- | | |
|--------------------|-----------------------|
| ① Headrest | ⑪ Backrest Cover |
| ② Backrest | ⑫ Back Support |
| ③ Armrest (Left) | ⑬ Rear Flange Cover |
| ④ Seat | ⑭ Rotation Lock Lever |
| ⑤ Seat Cover | ⑮ Main Switch Panel |
| ⑥ Flange Cover | ⑯ Main Switch |
| ⑦ Base | ⑰ Fuse Holder |
| ⑧ Upper Link Cover | ⑱ Foot Switch |
| ⑨ Lower Link Cover | ⑲ Power Supply Cable |
| ⑩ Pump Cover | |

2. DIMENSIONS AND SPECIFICATIONS

2-1. DIMENSIONS

-mm-

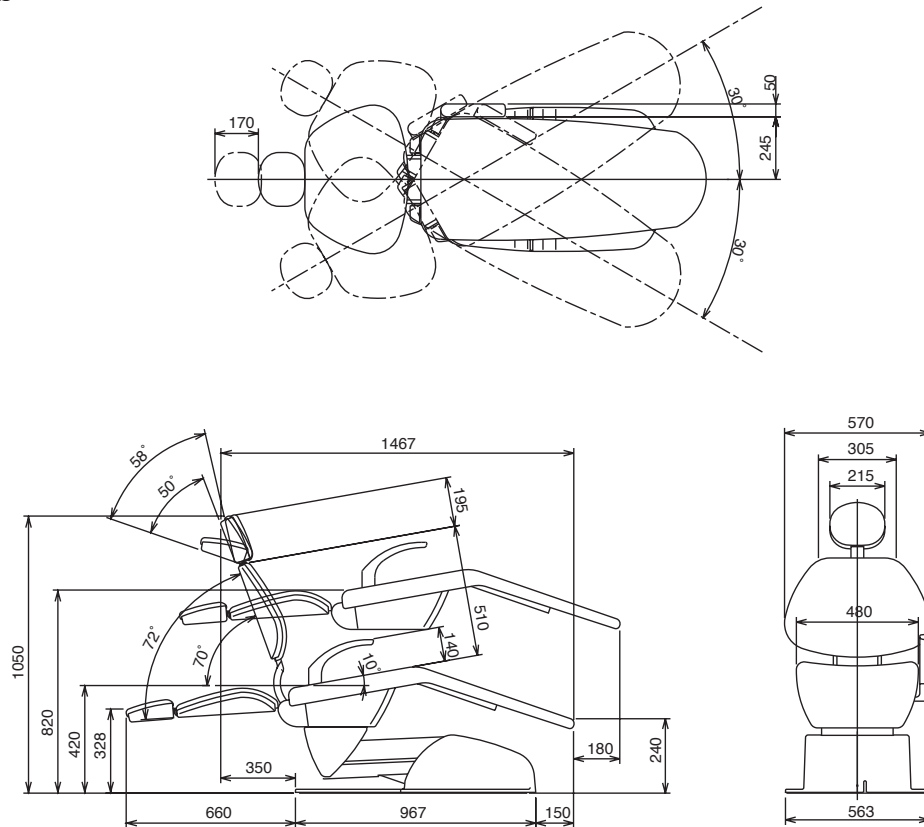

Fig.2-1 Dimensions

2-2. SPECIFICATIONS

Seat Initial Height-----	420mm
Seat Lifting Stroke-----	400mm
Backrest Movement -----	-2° ~ 70° above Horizontal
Auto Movements-----	2 Preset, 1 Last Position Memory and 1 Auto Return
Control Voltage-----	DC12V
Power Consumption -----	AC230V, 50/60Hz, 2.0/2.0A
Fuse -----	5A/250V(Current Rating:50A at 250VAC) Fast-blow
Net Weight-----	160 kg
Maximum Load -----	135 kg
Class of Foot Switch -----	IPX1 (applicable standards,IEC60529)
Applied Parts -----	Type B applied part : Seat for chair
Mode of Operation-----	Non-Continuous Operation/ON time:3 min, OFF time:15min
Service Life-----	10 years

3. OPERATING INSTRUCTIONS

3-1. MAIN SWITCH (Fig.1-1 & Fig.3-1)

Turn on the main switch located the left side pump cover.

A green lamp in the main switch illuminates.

CAUTION

**Operate the main switch only by hand.
Turn off the main switch after daily operation.**

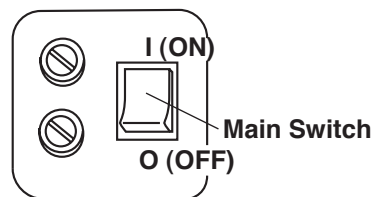

Fig.3-1 Main Switch

3-2. CONTROLS (Fig.3-2)

CAUTION

**Before operating the chair, confirm safety
for the patient and the operator.**

All chair electrical movements can be controlled by the foot switch.

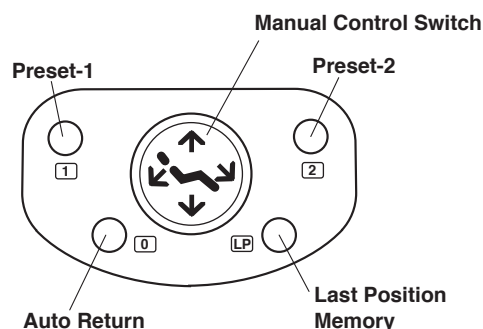

Fig.3-2 Foot Switch

(1) Manual Mode Control

A. Seat Lifting

Keep depressing (↑) side of the foot switch disc until the seat is lifted up to the desired position.

B. Seat Lowering

Keep depressing (↓) side of the foot switch disc until the seat is lowered to the desired position.

C. Backrest Reclining

Keep depressing (↙) side of the foot switch disc until the backrest is reclined to the desired position.

D. Backrest Raising

Keep depressing (↘) side of the foot switch disc until the backrest is raised up to the desired position.

(2) Auto Mode Control

E. Preset Control

PROGRES chair has two preset positions. (Preset-1 and Preset-2)

Momentarily depress (1) button on the foot switch, the chair will move to the preset-1 position automatically. (Preset-2 is operated by (2) button.)

F. Auto Return

Momentarily depress (0) button on the foot switch, the chair will return to the initial position (The seat is fully lowered and the backrest is upright position.),

G. Last Position Memory

Momentarily depress (LP) button at treatment position, the backrest will move to the mouth rinsing position automatically.

Momentarily depress (LP) button again, the backrest will return to the previous treatment position automatically.

H. Emergency Stop

During automatic procedure (Preset, Auto return and Last position memory), depressing any side of disc or button on the foot switch will cancel the automatic movement immediately.

Note : Do not keep depressing auto mode button (**1**) (**2**) (**0**) (**LP**) over 3 seconds.

Memorized position in auto mode may be changed.

3-3. SAFETY LOCK DEVICE (Fig.3-3)

All chair movements can be stopped automatically by the safety lock device when pressure is detected between the base and the lower link cover.

In case working the safety lock device, lift up the seat and remove a cause of pressure.

Note : Seat lifting and backrest raising can be operated when the safety lock device is working.

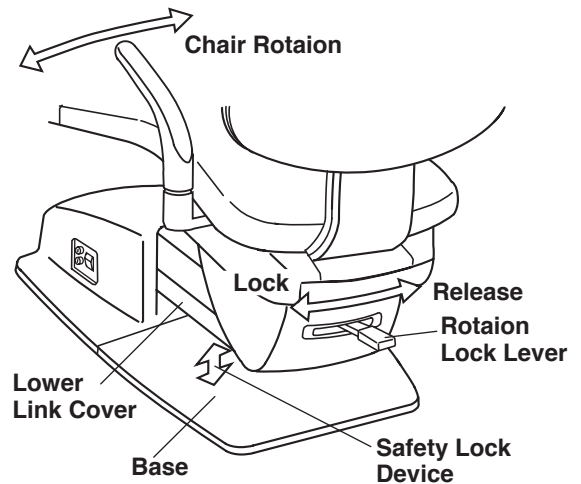

Fig.3-3 Safety Lock Device and Chair Rotation

3-4. CHAIR ROTATION (Fig.3-3)

Pull the rotation lock lever to right.

The upper structure can be rotated up to 30 degrees each in right and left.

Pull the rotation lock lever to left to lock the chair.

3-5. HEADREST (Fig.3-4)

(1) Height Adjustment

Press down or pull up the headrest to the desired height.

(2) Angle Adjustment

Push the headrest forward as required.

Lift the headrest lever to rotate backward and release the lever at the desired angle.

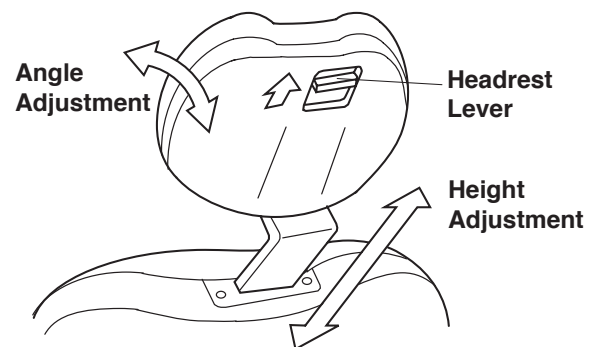

Fig.3-4 Headrest

⚠ CAUTION

Support the headrest with a hand when lifting headrest lever to prevent sudden drop.

4. AUTO MODE POSITION ADJUSTMENT

(1) Preset position Adjustment (Fig.4-1)

Two preset positions can be set.

- A. Set the seat and the backrest to the desired preset position by manual control switch.
- B. Keep depressing Preset-1 switch (1) until buzzer sounds (in about 3 seconds), then release it.
- C. The position is memorized for Preset-1.
- D. Preset-2 can be memorized by depressing preset-2 switch (2), as following A to C.

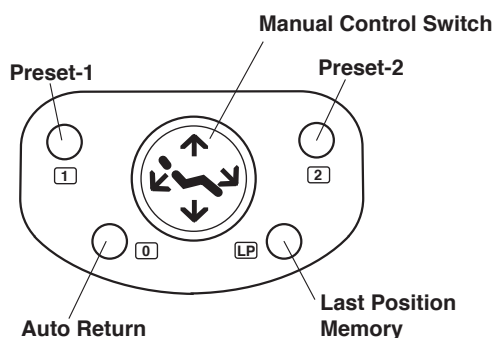

Fig.4-1 Foot Switch

(2) Mouth Rinsing Position Adjustment (Fig.4-1)

Mouth rinsing position in last position memory movement can be adjusted.

- A. Set the backrest to the desired mouth rinsing position by manual control switch.
- B. Keep depressing last position memory switch (LP) until buzzer sounds (in about 3 seconds) and release it.
- C. This backrest position is then memorized as the mouth rinsing position.

5. CARE AND MAINTENANCE

Chair Cleaning

- The surface of the chair's seating area is made of synthetic leather. Apply dry wiping or wipe the surface with cloth moistened with either water or diluted neutral detergent for the care.
- If the color of clothing or belt remained on the synthetic leather, wipe it off with cloth moistened with diluted neutral detergent as soon as possible, to avoid its penetration caused by plasticizer.
- In case the synthetic leather is wiped with a wet cloth, fully wipe off the moisture. If it remains, hydrolytic degradation may be accelerated. Do not use solvent or bleach.
- Apply dry wiping using a dry and soft cloth to metallic areas. If any metallic area is wetted, wipe off the moisture as soon as possible. It will rust otherwise.
- Wipe the resin cover with a wet and soft cloth.

Chair Sterilization

Use FD333 made by Durr sprayed to a soft cloth or paper towel for cleaning and sterilization of the product exterior. Do not operate the product until the liquid used for sterilization has fully dried up.

⚠ CAUTION

Do not place any hard and heavy article or any article having a sharp tip or edge on the chair's seating area. The synthetic leather may be damaged otherwise.
For cleaning the resin cover, do not use solvent or detergent containing abrasive agent. In addition, do not use any chemical that is other than specified for this unit. The resin cover may crack otherwise.
Use a soft cloth moistened with either water or diluted neutral detergent. Never use detergent of strong acidity or alkali pipe detergent, or materials including metal may be corroded.

⚠ CAUTION

Turn OFF the main switch at the lowest seat position after daily operation and for a long term interval.

6. MAINTANANCE AND INSPECTION

6-1. Guide for daily maintenance and inspection (Maintenance and inspection by user)

Management of maintenance and inspection of medical equipment should be implemented by the user (medical institution). In case the user does not implement such management, it is permitted that such management is outsourced to a qualified entity such as a medical equipment repair company.

For safe use of this product, it is necessary that inspection should be conducted in the specified frequency on the items described below.

No.	Item	Frequency	Inspection method and diagnosis	Influence if inspection not conducted	Maintenance required in case of nonconformity
1	Check of safety functions	Before start	During pre-set movement or auto-return movement, press any key for chair operation and the chair should automatically stop.	Unexpected personal injury and troubles may arise due to motion of the chair during medical treatment and due to pinching between doctor section and chair.	Contact your dealer or our office if any abnormality arises.
2	Power supply cable	Before start	Power supply cable should not be abnormally bent, pinched or damaged, and the plug should be firmly inserted to the power outlet and not covered with dust.	Accident or defect of the equipment	Clean and rearrange the cable. For replacement, contact your dealer or our office.
3	Function of each switch	Before start	Each switch for chair operation should work correctly.	Defect of movement may cause an accident.	Contact your dealer or our office if any abnormality arises.
4	Moving parts	Before start	Make sure that the chair does not make any abnormal noise during automatic and manual movement	Accident or defect of the equipment	Contact your dealer or our office if any abnormality arises.
5	Oil leakage	Before start	Make sure that there is no hydraulic oil on the floor or chair base leaking from the cylinder.	Defect of the equipment	Contact your dealer or our office if any abnormality arises.
6	Wiping off water	After closing	Make sure that no water is left that were spilt during treatment.	Water will cause rust	Wipe off water with a soft and dry cloth.
7	Stain removal of external parts	After closing	Visual check the attachment of dust, chemicals or drug and grasp the total product condition	Discoloration, transformation or breakage of resin parts may arise.	Clean up according to the "CARE AND MAINTANANCE " in operating instructions.
8	Main power switch	After closing	Make sure that the main power switch is off	Accident or defect of the equipment	In the case the main power cannot be turned off, contact your dealer or our office.

6-2. Guide for Periodical Check-up

- Some parts and components of the products are degraded or deteriorated depending on the frequency of use. Annual check-up and maintenance, as well as replacement of consumable parts, are required.
- The required parts (including consumable parts) are listed below. It may be different from the following list depending on the option of the unit.
- For check-up and repair, call a technician of our authorized dealer.

Parts and components that require periodical check-up

No.	Parts Description	Standard Lifetime
1	Moving part	7 years
2	Electric wiring of moving parts	5 years
3	Switches	5 years
4	Control PCBs	5 years

Consumable parts

No.	Parts Description
1	O-ring, Packing, Diaphragm

WARNING

Execute the maintenance in accordance with this instruction manual and operating manual attached to each individual equipment (Dental light, Handpiece, etc..) .
Failure to maintain this product may lead to physical injury or property damage.

7. BEFORE ASKING FOR REPAIRS

If any of phenomena described below has occurred, make the following checks before asking for repairs.

Phenomenon	Check point and result	Action to be taken
The product does not work at all.	Main switch is not on.	Turn on the main switch.
	Equipment circuit breaker in the clinic cabinet panel is not on.	Turn on the equipment circuit breaker.
The chair does not work.	Locking device for motion stop is activated.	Unlock the device. See section for SAFETY LOCK DEVICE.

If the unit does not normally work even if actions were taken upon checkup stated above, then stop using the unit, turn off the main switch and contact your dealer or our office.

8. ELECTROMAGNETIC COMPATIBILITY(EMC)

Medical electrical equipment needs special precautions regarding EMC and needs to be installed and put into service according to the EMC information provided in this manual.

Portable and mobile RF communications equipment can affect medical electrical equipment.

The equipment or system should not be used adjacent to or stacked with other equipment. If adjacent or stacked use is necessary, the equipment or system should be observed to verify normal operation in the configuration in which it will be used.

Guidance and manufacture's declaration - electromagnetic emissions		
The PROGRES is intended for use in the electromagnetic environment specified below. The customer or the user of the PROGRES should assure that it is used in such an environment.		
Emissions test	Compliance	Electromagnetic environment - guidance
RF emissions CISPR 11	Group 1	The PROGRES uses RF energy only for its internal function. Therefore, its RF emissions are very low and are not likely to cause any interference in nearby electronic equipment.
RF emissions CISPR 11	Class B	The PROGRES is suitable for use in all establishments, including domestic establishments and those directly connected to the public low-voltage power supply network that supplies buildings used for domestic purposes.
Harmonic emissions IEC 61000-3-2	Class A	
Voltage fluctuations/ Flicker emissions IEC 61000-3-3	Complies	

Guidance and manufacture's declaration – electromagnetic immunity			
The PROGRES is intended for use in the electromagnetic environment specified below. The customer or the user of the PROGRES should assure that it is used in such an environment.			
Immunity test	IEC 60601 test level	Compliance level	Electromagnetic environment - guidance
Electrostatic discharge (ESD) IEC 61000-4-2	±6 kV contact ±8 kV air	±6 kV contact ±8 kV air	Floors should be wood, concrete or ceramic tile. If floors are covered with synthetic material, the relative humidity should be at least 30%.
Electrical fast transient/burst IEC 61000-4-4	±2 kV for power supply lines ±1 kV for input/output lines	±2 kV for power supply lines ±1 kV for input/output lines	Mains power quality should be that of a typical commercial or hospital environment.
Surge IEC 61000-4-5	±1 kV differential mode ±2 kV common mode	±1 kV differential mode ±2 kV common mode	Mains power quality should be that of a typical commercial or hospital environment.
Voltage dips, short interruptions and voltage variations on power supply input lines IEC 61000-4-11	<5% U_T (>95% dip in U_T) for 0.5 cycle 40% U_T (60% dip in U_T) for 5 cycle 70% U_T (30% dip in U_T) for 25cycle <5% U_T (>95% dip in U_T) for 5 s	<5% U_T (>95% dip in U_T) for 0.5 cycle 40% U_T (60% dip in U_T) for 5 cycle 70% U_T (30% dip in U_T) for 25cycle <5% U_T (>95% dip in U_T) for 5 s	Mains power quality should be that of a typical commercial or hospital environment. If the user of the PROGRES requires continued operation during power mains interruptions, it is recommended that the PROGRES be powered from an uninterruptible power supply or a battery.
Power frequency (50/60 Hz) magnetic field IEC 61000-4-8	3 A/m	3 A/m	Power frequency magnetic fields should be at levels characteristic of a typical location in a typical commercial or hospital environment.
NOTE U_T is the a.c. mains voltage prior to applications of the test level.			

Guidance and manufacture's declaration - electromagnetic immunity

The PROGRES is intended for use in the electromagnetic environment specified below. The customer or the user of the PROGRES should assure that it is used in such an environment.

Immunity test	IEC 60601 test level	Compliance level	Electromagnetic environment - guidance
Conducted RF IEC 61000-4-6	3 Vrms 150 kHz to 80 MHz outside ISM bands ^a	3 Vrms	<p>Portable and mobile RF communications equipment should be used no closer to any part of the PROGRES, including cables, than the recommended separation distance calculated from the equation applications to the Frequency of the transmitter.</p> <p>Recommended separation distance $d = 1.2 \sqrt{P}$</p>
Radiated RF IEC 61000-4-3	3V/m 80 MHz to 2.5 GHz	3 V/m	<p>$d = 1.2 \sqrt{P}$ 80 MHz to 800 MHz $d = 2.3 \sqrt{P}$ 800 MHz to 2.5 GHz</p> <p>Where P is the maximum output power rating of the transmitter in watts (W) according to the transmitter manufacturer and d is the recommended separation distance in metres (m).</p> <p>Field strengths from fixed RF transmitters, as determined by an electromagnetic site survey,^a should be less than the compliance level in each frequency range.^b</p> <p>Interference may occur in the vicinity of equipment marked with the following symbol:</p> <div style="text-align: center;">  </div>

NOTE 1 At 80 MHz and 800MHz, the higher frequency range applies.

NOTE 2 These guidelines may not apply in all situations. Electromagnetic propagation is affected by adsorption and reflection from structures, objects and people.

- a Field strengths from fixed transmitters, such as base stations for radio (cellular/cordless) telephones and land mobile radios, amateur radio, AM and FM radio broadcast and TV broadcast cannot be predicted theoretically with accuracy. To assess the electromagnetic environment due to fixed RF transmitters, an electromagnetic site survey should be considered. If the measured field strength in the location in which the PROGRES is used exceeds the applicable RF compliance level above, the PROGRES should be observed to verify normal operation. If abnormal performance is observed, additional measures may be necessary, such as reorienting or relocating the PROGRES.
- b Over the frequency range 150 kHz to 80 MHz, field strengths should be less than 3V/m.

Essential performance (purpose of IMMUNITY testing)

Unless operated by the switches for chair control, the PROGRES does not make any movements, except for sounding a buzzer and switching on/off the indicator.

**Recommended separation distances between
Portable and mobile RF communications equipment and the PROGRES**

The PROGRES is intended for use in an electromagnetic environment in which radiated RF disturbances are controlled. The customer or the user of the PROGRES can help prevent electromagnetic interference by maintaining a minimum distance between portable and mobile RF communications equipment (transmitters) and the PROGRES as recommended below, according to the maximum output power of the communications equipment.

Rated maximum output power of transmitter W	Separation distance according to frequency of transmitter m		
	150 kHz to 80 MHz $d = 1.2 \sqrt{P}$	80 MHz to 800 MHz $d = 1.2 \sqrt{P}$	800 MHz to 2.5 GHz $d = 2.3 \sqrt{P}$
0.01	0.12	0.12	0.23
0.1	0.38	0.38	0.73
1	1.2	1.2	2.3
10	3.8	3.8	7.3
100	12	12	23

For transmitters rated at a maximum output power not listed above, the recommended separation distance d in metres (m) can be estimated using the equation applicable to the frequency of the transmitter, where P is the maximum output power rating of the transmitter in watts (W) according to the transmitter manufacturer.

NOTE 1 At 80 MHz and 800MHz, the separation distance for the higher frequency range applies.

NOTE 2 These guidelines may not apply in all situations. Electromagnetic propagation is affected by adsorption and reflection from structures, objects and people.

NOTE



Takara Belmont (UK) Ltd.

Bemont House
One St.Andrews Way, Bow,
London E3 3PA U.K.
Tel : (44) 20-7515-0333
Fax : (44)20-7987-3596



Belmont

TAKARA BELMONT CORPORATION
2-1-1, Higashishinsaibashi, Chuo-ku, Osaka, 542-0083, Japan
TEL : 81-6-6213-5945
FAX : 81-6-6212-3680

BOOK NO. AEFT04H0
Printed in Japan 2012.04